

777F

Off-Highway Truck



Engine

Engine Model	Cat [®] C32 ACERT™	
Gross Power – SAE J1995	758 kW	1,016 hp
Net Power – SAE J1349	700 kW	938 hp

Weights – Approximate

Target Gross Machine Operating Weight	163 293 kg	360,000 lb
---------------------------------------	------------	------------

Operating Specifications

Nominal Payload Class	90.7 tonnes	100 tons
Body Capacity – SAE 2:1	60.2 m ³	78.8 yd ³

- Refer to the Caterpillar[®] 10/10/20 Payload Guidelines for maximum gross machine weight limitations.
- Capacity with dual slope body.

777F Off-Highway Truck

Engineered for performance, designed for comfort, built to last.

Power Train – Engine

- ✓ The Cat® C32 engine with ACERT™ Technology uses advanced engine technology to reduce emissions without after-treatment. The turbocharged, aftercooled 12-cylinder engine has higher horsepower and faster response for superior performance in demanding applications. **pg. 4**

Power Train – Transmission

- ✓ The Cat® seven-speed power shift transmission matched with the Cat C32 engine with ACERT Technology provides constant power and efficiency over a wide operating speed range for optimal power train performance. **pg. 5**

Structures

- ✓ The 777F features a mild-steel, box-section type frame, proven on the 777D to deliver durability and long life with low operating costs. Castings and forgings are strategically placed in high-stress areas to evenly distribute stresses and provide long fatigue life. **pg. 6**

Serviceability

- ✓ The 777F offers 500-hour engine service intervals – 250 hours more than the 777D. Simplified service and maintenance features combined with improved service access are designed to reduce downtime. **pg. 12**

Information & Monitoring Systems

- ✓ Standard on the 777F, the Cat Messenger system provides real-time engine performance and operating data. The 777F also offers the optional VIMS™ Advisor monitoring system, providing data for more than 250 machine functions. **pg. 13**

Top Performance.

Developed specifically for mining, quarry and construction applications, the 777F keeps material moving at high volume to lower cost-per ton.

Reliable, Durable, Dependable.

Rugged construction and easy maintenance procedures ensure long life with low operating costs.



Operator's Station

- ✓ The 777F features an all new operator station with enhanced visibility, increased operator space and ergonomically designed controls that set new industry standards for operator comfort. All controls and gauges are positioned for optimum efficiency and total machine control. **pg. 7**

Engine – Power Train Integration

- ✓ The Cat Data Link electronically combines engine, transmission, brake and operational information to optimize overall truck performance. Stored diagnostic data can be accessed via the Cat Electronic Technician (Cat ET) service tool to improve troubleshooting and reduce downtime. **pg. 8**

Brake System

- ✓ Cat oil-cooled, multiple disc brakes are now hydraulically controlled, reducing maintenance costs and improving operator control and modulation. They provide exceptional, fade-resistant braking and retarding for maximum performance and productivity in all haul-road conditions. **pg. 10**

Truck Body Systems

- ✓ The 777F can be configured with the Dual Slope, X Body or Gateless Coal Body. This full line of body options ensures that the body is matched to specific application requirements. **pg. 14**

Customer Support

- ✓ Cat dealers provide unmatched product support, anywhere in the world. With industry-best parts availability and a wide range of maintenance and service options, Cat dealers have what it takes to keep your hauling machines productive. **pg. 16**

Safety

- ✓ Caterpillar sets the standard when it comes to safety in the design and manufacturing of heavy equipment. Safety is not an afterthought at Caterpillar, but an integral part of all machine and systems designs. **pg. 17**



✓ *New Feature*

Power Train – Engine

The Cat® C32 engine with ACERT™ Technology is built for power, reliability and efficiency for superior performance in the toughest applications.



Cat® C32 engine with ACERT™ Technology. With the C32 engine, Caterpillar optimizes engine performance while meeting U.S. EPA Tier 2 and European Union Stage II regulations. ACERT™ Technology reduces emissions during the combustion process by using advanced technology in the air and fuel systems, in conjunction with integrated electronics. Caterpillar meets emission regulations at the combustion source, rather than recycling exhaust.

Engine Design. The Cat C32 engine uses ACERT Technology and iron-specific features to deliver strong performance and long-term durability.

EPA Emissions Compliant. The C32 engine is compliant with U.S. EPA Tier 2 and European Union Stage II emissions regulations.

Altitude Compensation. Electronic engine control automatically compensates for load demand, high-altitude conditions and cold starting.

Single-Piece Piston Design.

New single-piece forged steel pistons with integrated forged steel skirt are more robust to withstand high engine heat and pressure, and enable enhanced combustion efficiency, improved fuel efficiency and lower emissions. Corrosion-resistant, stainless steel top ring reduces ring, groove and liner wear for greater reliability and longer life.

MEUI Fuel System. Fuel delivery, provided by the MEUI mechanically actuated electronic unit injection system, involves a high degree of precision. Precisely shaping the combustion cycle lowers combustion chamber temperatures, generating fewer emissions and optimizing fuel combustion. The system senses operating conditions and regulates fuel delivery for optimum fuel efficiency, improved response times, lower emissions and less smoke.

Electronic Control Module (ECM).

ECM uses advanced engine management software to monitor, control and protect the engine using self-diagnosing electronic sensors. The computerized system senses operating conditions and power requirements and adjusts the engine for peak performance and the most efficient operation at all times.

Advanced Diesel Engine Management A4 Engine Controller.

The ADEM™ A4 electronic control module delivers optimum fuel performance. The engine management system provides flexible fuel mapping, allowing the engine to respond quickly to varying application needs. It tracks engine and machine conditions while keeping the engine operating at peak efficiency.

Oil Renewal System (optional). The oil renewal system meters and injects used engine oil from the crankcase to the engine's fuel return line, extending oil change intervals and increasing machine availability and productivity.

Power Train – Transmission

Cat power train delivers more power to the ground for greater productivity and lower operating costs.

Mechanical Power Train. The Cat mechanical drive power train and power shift transmission provides unmatched operating efficiency and control on steep grades, in poor underfoot conditions, and on haul roads with high rolling resistance.

Transmission. Pairing the Caterpillar seven-speed planetary power shift transmission with the C32 diesel engine with ACERT Technology delivers constant power over a wide range of operating speeds.

- **Long Life.** A dedicated transmission oil tank and circuit provides cooler, cleaner oil for maximum performance and longer component life.

- **Transmission Chassis Control (TCC).** TCC uses electronically transferred engine rpm data to execute shifts at preset points for optimum performance, efficiency and clutch life.

Lock-Up Torque Converter. Combines maximum rimpull and cushioned shifting of torque converter drive with the efficiency and performance of direct drive. The lock-up torque converter engages at approximately 8 km/h (5 mph), delivering more power to the wheels.

- **Lock-Up Clutch.** Quickly releases and re-engages to reduce power train torque loads for smoother shifting, long life and a more comfortable ride.

- **ECPC (Electronic Clutch Pressure Control) System.** ECPC modulates clutch engagement individually, allowing for smoother speed and directional shifts. ECPC provides controls for both the torque converter lock-up clutch and the transmission clutches that are tailored to each particular upshift or downshift. This provides the operator a superior ride and reduced fatigue.



Final Drives. Cat final drives work as a system with the planetary power shift transmission to deliver maximum power to the ground. Built to withstand the forces of high torque and impact loads, double reduction final drives provide high torque multiplication to further reduce drive train stress.

Steering System. Hydraulic steering control system is designed for exceptional smoothness and precise control. A separate circuit prevents cross contamination for long life.

- **Secondary Steering.** Battery powered secondary steering system allows up to three 90 degree turns in case of engine failure.

Wheels and Rims. Cast rear wheels and Cat center-mount rims are mounted using studs and nuts to minimize maintenance and maximize durability.

Structures

Rugged Cat structures are the backbone of the 777F off-highway truck's durability.

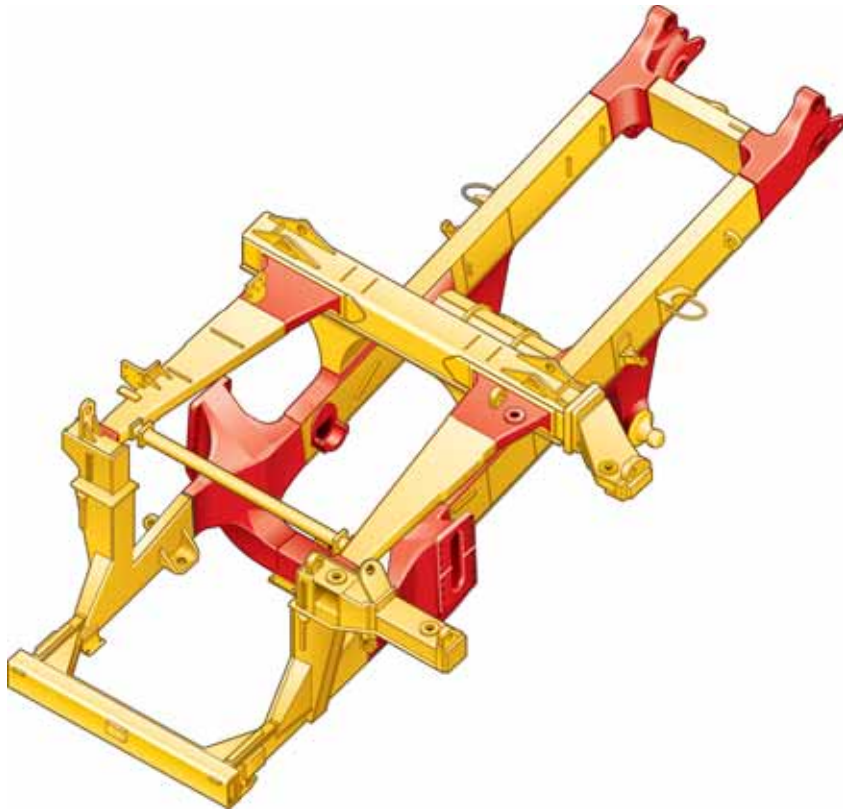

Box-Section Design. The 777F frame uses a steel box-section design, incorporating two forgings and 19 castings in high-stress areas with deep penetrating and continuous wrap-around welds to resist damage from twisting loads without adding extra weight.

- **Steel Structures.** Mild steel used throughout the frame provides flexibility, durability and resistance to impact loads, even in cold climates, and allows for easy field repairs.

- **Castings.** Castings have large radii with internal reinforcing ribs to dissipate stress in areas of high stress concentration. Castings move welds to lower stress areas for greater frame life.



Integral Four-Post ROPS Cab.

Resiliently mounted to the main frame with all-new cab mounts that reduce vibration and sound, the integral ROPS is designed as an extension of the truck frame. The ROPS/FOPS structure provides “five-sided protection” for the operator.

Suspension System. Designed to dissipate haul-road and loading impacts for longer frame life and a more comfortable ride.

- **Cylinders.** Four independent self-contained, oil pneumatic, variable-rebound suspension cylinders are designed to absorb shocks in the most severe applications.

- **Durable Design.** Rugged cylinders use a large diameter bore and low pressure nitrogen/oil design for long life with minimal maintenance.

- **Front.** Front cylinders with preset caster and camber are mounted to the frame and serve as steering kingpins for a tight turning radius with excellent maneuverability and low maintenance.

- **Rear.** Rear cylinders allow axle oscillation and absorb bending and twisting stresses caused by uneven and rough haul roads rather than transmitting them to the frame.

Technology Enhanced. Caterpillar structures are tested using System Structural Analysis (SSA) to dynamically simulate operations in field environments and identify potential structural improvements in high stress areas. With analysis of machine structures and variables, such as haul road and payload, structural improvements were made to the frame to accommodate the new cab, platform, engine and radiator.

Quality Control. A Coordinate Measuring Machine (CMM) is used to inspect truck frames for consistency in the manufacturing process. Easy rebuild ability is thereby achieved by ensuring the frames are within tolerance, removing the need to alter down-stream parts.

Operator's Station

Ergonomically designed for operator comfort, superior control and high productivity.

Ergonomic Layout. The 777F operator station is ergonomically designed for total machine control in a comfortable, productive and safe environment. All controls, levers, switches and gauges are positioned to maximize productivity and minimize operator fatigue.

New ISO Designed Cab Mounts. Integral, sound-suppressed cab is resiliently mounted to the frame to isolate the operator from sound and vibration for a quiet, secure and comfortable ride.

Viewing Area. Designed for excellent all-around visibility and clear sight lines to the haul road. The large viewing area, with 100 percent more glass, enables the operator to maneuver with confidence for greater productivity.

Air Suspension Seat w/Three-Point Operator Restraint. Ergonomically designed, fully adjustable air suspension seat with adjustable armrests provides optimal driving comfort. A wide, retractable 3-point seat/shoulder belt provides a secure, comfortable restraint.

Hoist Lever. Four-position, low effort electronic hoist control system is positioned next to the gear selector in the right-hand console.

Secondary Brake Pedal. Conveniently located on the floor for easy operator control.

Steering Column. Comfortable steering wheel with tilt and telescoping function provides a comfortable driving position for all operators.

Transmission Console. Ergonomic gear shift lever with backlit gear indicators provides easy operation. The parking brake function is integrated into the gear selector.

Trainer Seat. The trainer seat is relocated to the left of the operator, which allows trainer to use same stairway.



When not in use, the fold-down trainer seat creates a working surface with cup holder. The seat also folds up, providing more room for the operator. Under seat storage is convenient for stowing a lunch box.

Operator Controls. Easy to reach turn signal, high beam, intermittent windshield wiper and windshield washer controls are located on the left side of the steering column, and are designed for optimum efficiency and comfort.

Heating/Air Conditioning. Electronically controlled, four-speed fan and 13 vents deliver temperature-controlled air circulation for a comfortable working environment in any climate. Electronic controls reduce maintenance. More robust air compressor offers a 25 percent increase in capacity, greater durability and longer life.

Radio Ready. Cab is prewired with power converter, speakers, wiring harness, antenna and necessities for add-on communication systems.

Multiple Power Ports. Power ports are conveniently located in three locations in the cab: one in the right-hand console, two behind the trainer seat, and one in the dash.

Truck Production Management System (TPMS) (optional). TPMS provides valuable payload and cycle time data, which is viewed through Messenger or VIMS Advisor to improve productivity.

Engine – Power Train Integration

This system electronically combines critical power train components to work together more intelligently to optimize overall truck performance.

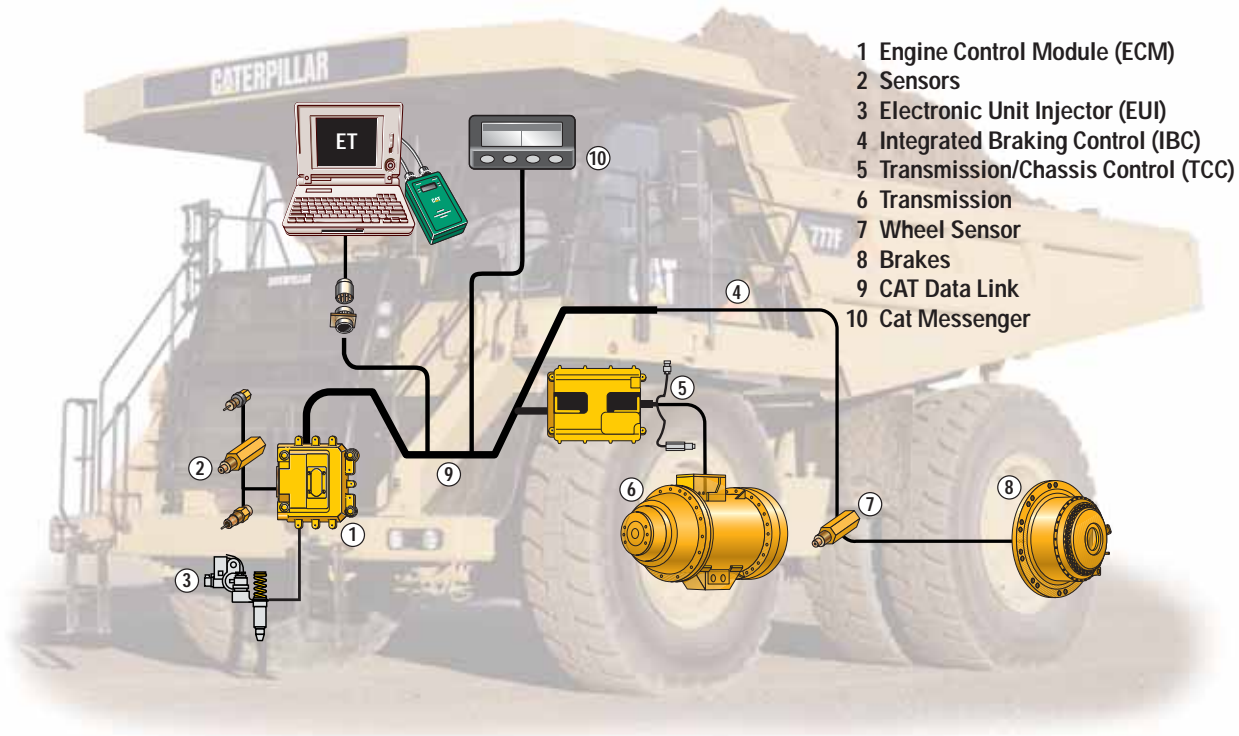

Cat Data Link. Electronically integrates machine computer systems to optimize overall power train performance, increase reliability and component life, and reduce operating costs. All control modules communicate via the Cat Data Link and work together as an integrated system to maximize production efficiency and extend component life.

Transmission Chassis Control (TCC). TCC uses electronically transferred engine rpm data to execute shifts at preset points for optimum performance, efficiency and clutch life.

Electronic Technician (Cat ET). Cat ET service tool provides service technicians with easy access to stored diagnostic data through the Cat Data Link to simplify problem diagnosis and increase machine availability.

Controlled Throttle Shifting. Regulates engine rpm during shifting to reduce power train stress and clutch wear by controlling engine speed, torque converter lock-up, and transmission clutch engagement for smoother shifts and longer component life.

Directional Shift Management.

Regulates engine speed during directional shifts to prevent damage caused by high-speed directional changes.

Neutral Coast Inhibitor. Prevents the transmission from shifting to neutral at speeds above 6.5 km/h (4 mph), protecting the transmission from operating with insufficient lubrication.

Body-up Shift Limiter. Prevents the transmission from shifting above a pre-programmed gear without the body being fully lowered. This function is programmable via Cat Electronic Technician (Cat ET) and Messenger or Advisor.

Body-up Reverse Neutralizer.

Automatically shifts the transmission to neutral if the hoist lever is activated while the transmission is shifted in reverse.

Overspeed Protection. The transmission control electronically senses engine conditions and automatically up-shifts one gear to prevent overspeeding.

If overspeeding occurs in the top gear, the lock-up clutch is disengaged, and the brakes are applied.

Programmable Top Gear. Transmission top gear maximum can be set using Cat Messenger, VIMS Advisor or the Cat ET service tool to help the operator maintain speed limits.

Anti-Hunt Function. This function minimizes shifting by not allowing the transmission to up or down shift immediately after a shift has occurred. This prevents gear hunting when operating near a shift point and minimizes transmission shifting for increased component life.

Downshift Inhibitor. Prevents engine overspeeding by keeping the transmission from downshifting until engine speed reaches the downshift point.

ECPC Control. Both the torque converter lock-up clutch and the transmission clutches now have software-control for clutch fill and slip characteristics to provide superior smooth shifting.

Economy Shift Mode. Modifies engine maps for greater fuel economy.

Reverse Shift Inhibitor. Protects the engine from abrupt directional changes by slowing down the engine before shifting the transmission into reverse.

Cat Messenger. Critical data from the engine and transmission, including transmission shifting, engine speed and fuel consumption, provides service technicians with enhanced diagnostic capability, through Cat Messenger, to reduce downtime and operating costs.

Traction Control System (TCS) (optional). TCS electronically monitors and controls rear wheel slippage for greater traction and enhanced truck performance in poor underfoot conditions.

Brake System

Reliable braking with superior control gives the operator the confidence to focus on productivity.



Integrated Braking System. The Cat oil-cooled braking system delivers reliable performance and control in the most extreme haul-road conditions. The integrated system combines the service, secondary, parking brake and retarding functions in the same system for optimum braking efficiency.

Oil-Cooled Multiple Disc Brakes. Caterpillar hydraulically controlled four-wheel, forced oil-cooled, multiple disc service brakes are continuously cooled for exceptional, non-fade braking and retarding performance.

Extended Life Disc Brakes (optional). Extended life friction material has double the wear life of standard brakes and is twice as resistant to glazing for more consistent braking power with less noise.

Brake Design. Cat oil-cooled disc brakes are designed with large discs and plates for reliable, adjustment-free operation and performance. Brakes are completely enclosed and sealed to prevent contamination and reduce maintenance.

Long Life. An oil film prevents direct contact between the discs. This design absorbs the braking forces by shearing the oil molecules and carrying heat away to extend brake life.

Pistons. The Caterpillar two-piece piston design combines the service, secondary, parking brake and retarding functions in the same system. The primary piston hydraulically actuates both service and retarding functions. The secondary piston is spring-applied and held in the disengaged position by hydraulic pressure. If hydraulic system pressure drops below a specified level, the spring-applied secondary piston automatically applies the brakes.

Parking Brake. Oil-cooled, spring-applied, hydraulically released parking brake is applied to the rear wheels for superior parking capability on all grades up to 15 percent.

Four Corner Retarding. Four corner retarding with 60/40 percent split (rear/front) in braking effort provides superior control in slippery conditions. Balanced front to rear brake torque provides exceptional braking performance and minimizes wheel lock-up, especially during retarding.

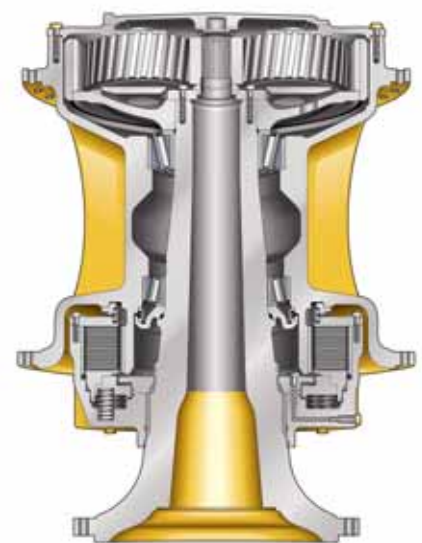

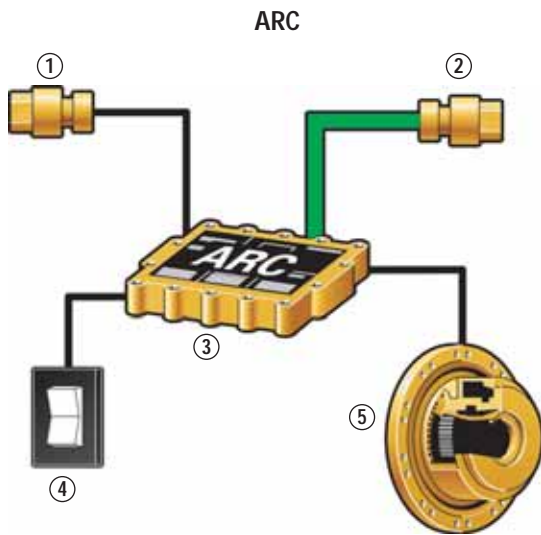

- 1 Service Brake Sensor
- 2 Engine Sensor
- 3 ARC
- 4 ARC Switch
- 5 Brakes
- 6 Service Brakes
- 7 Axle Speed Sensor
- 8 TCS

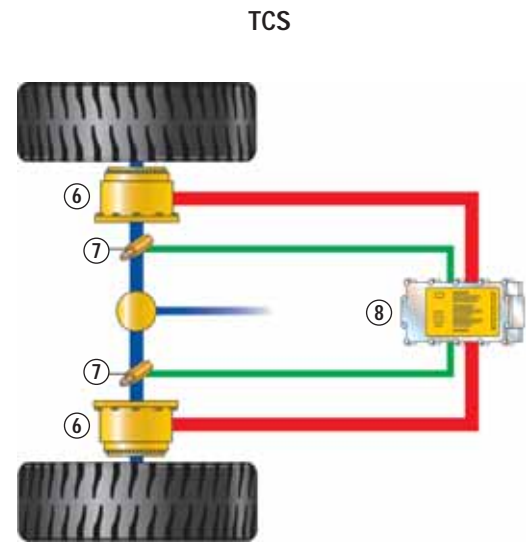

Automatic Retarder Control (ARC).

Standard ARC electronically controls braking on grade to maintain engine at approximately 1,950 rpm (adjustable from 1,850-1,950 rpm). ARC is deactivated when the operator applies the brakes or throttle.

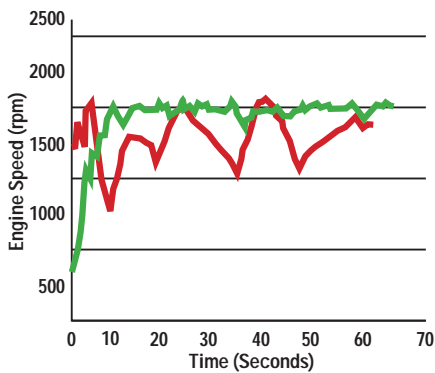

- With Automatic Retarder Control (average speed, 1950 rpm)
- With Manual Retarder Control (average speed, 1730 rpm)

• **Faster Speeds.** ARC allows the operator to maintain optimum engine speeds for up to 15 percent faster downhill hauls and greater productivity.

• **Superior Control.** Automatic brake modulation offers a smoother ride and better control in slippery conditions, allowing the operator to concentrate on driving.

• **Ease of Operation.** ARC increases operating ease, resulting in greater operator confidence with less fatigue.

• **Engine Overspeed Protection.** Automatically activates ARC when engine speed exceeds factory preset levels, regardless of operator inputs, to avoid potentially damaging engine overspeeds.

Traction Control System (TCS) (optional).

Electronically monitors and controls rear wheel slippage for greater traction and enhanced truck performance in poor underfoot conditions. If slippage exceeds a set limit, the oil-cooled disc brakes engage to slow the spinning wheel. Torque is then automatically transferred to the wheel with better traction.

• **Differential Action.** Normal differential action provides superior maneuvering and control in slippery conditions.

• **Compression Brake (optional).** Optional Compression Brake is integrated with Automatic Retarder Control (ARC) to provide up to 35 percent higher downhill travel speed and reduce wear on brake components.

Serviceability

Less time spent on maintenance means more time on the haul roads.



Servicing Ease. Easy access to daily service points simplifies servicing and reduces time spent on regular maintenance procedures. Enhanced serviceability and extended 500-hour service intervals are designed to increase machine availability and productivity. Engine-overhaul costs are also reduced up to 25 percent.

Maintenance Platform. Easy stairway access to engine, air filters, steering hydraulic tank and radiator.

Ground-Level Access. Allows convenient servicing to tanks, filters, drains, battery disconnect and engine shutdown.

Engine Prelube. Engine prelubrication provides engine oil pressure prior to engine cranking. This reduces engine dry and cold start wear, and reduces engine component wear.

Fast Fill Service Center (optional).

Wiggins fast fill service center features high-speed fuel and oil exchange and clustered connections for fluids for fast, accurate servicing and reduced downtime.

Oil Renewal System (ORS) (optional).

Extends oil change intervals and reduces waste oil handling by continuously burning oil from the engine oil pan through normal engine operation. New oil is continually added to compensate for oil burned.

Scheduled Oil Sampling. S•O•SSM sampling valves speed sampling and analysis reliability.

Pressure Test Points. Disconnect valves are conveniently located throughout the hydraulic systems for easy pressure testing. New ECPC transmission provides multiple pressure taps outside the transmission.

Air Filters. Radial seal air filters are easy to change, reducing time required for air filter maintenance.

On-Board Diagnostic Systems.

Messenger continuously checks all critical machine functions and components, and helps locate faults quickly for faster repair. Electronic control system enables quick diagnosis of engine conditions and effective maintenance and repairs using the Electronic Technician (Cat ET) tool.

Lincoln's Centro-Matic Automatic

Lubrication (optional). This advanced lubrication system is available as a factory installed option on the 777F. It includes an electronically controlled pump and adjustable injectors to dispense a precise amount of lubricant to each lubrication point.

Clustered Grease Fittings (optional).

Clustered grease fittings save time as all lubrication points are mounted in three main locations.

Next Generation Modular Radiator

(NGMR). This cooling system's new modular design permits removal of a single core without removing the entire radiator, reducing downtime and repair costs. NGMR also offers wider fin spacing for greater resistance to plugging and more convenient cleaning.

QuickEvac™ System. Oil change labor time is reduced by as much as 50 percent with this standard on-board engine oil evacuation and pre-lube system. It speeds the process of evacuating the engine sump and allows for the purging of oil filters prior to removal, minimizing oil spills. QuickEvac system also enhances contamination control by ensuring filtration of new oil on engine refill.

Reduced Maintenance Costs/Higher

Machine Availability. The C32 engine with ACERT Technology offers 500-hour service intervals under normal conditions. For the 777F, commonly used engine service points have been placed on the right side of the engine. Feedback from engine sensors provides data to the electronic controller. When engine data is out of spec, a warning is sent to the operator.

Information & Monitoring Systems

Vital machine health and payload data keeps the 777F performing at peak production levels.

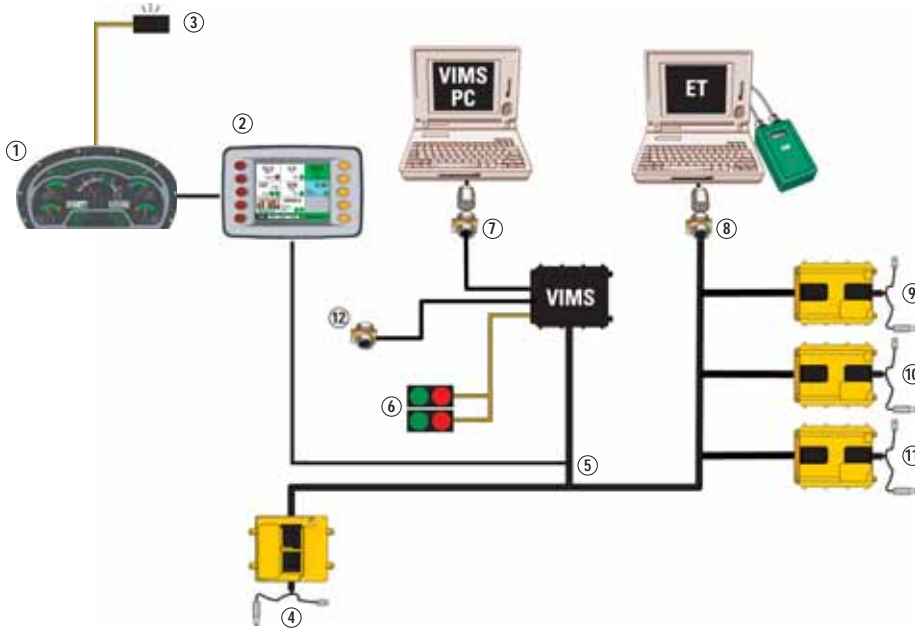

- 1 Gauge Cluster
- 2 Advisor Display
- 3 Action Alarm
- 4 ADEM A4 Engine Control Module
- 5 CAT Data Link
- 6 Payload Lamps
- 7 Data Port (VIMS-PC)
- 8 Diagnostic Connector (ET)
- 9 Road Analysis Control (RAC) Module (optional)
- 10 Transmission/Chassis Control (TCC) Module
- 11 Automatic Retarder Control (ARC) and Traction Control System (TCS)
- 12 Telemetry Port

Instrument Cluster. Critical operating information on the 777F is relayed via the Cat Data Link to five gauges, 18 LED indicator lights, and an LCD digital display.

Cat Messenger. Standard on the 777F, Cat Messenger provides real-time machine performance and operating data, and basic trip, maintenance, and diagnostic data using an LCD display. The viewable LCD screen area of the Messenger display is 22.5 mm × 84.6 mm (0.89 in × 3.33 in).

Truck Production Management System (TPMS) (optional). TPMS provides valuable payload and cycle time data to improve productivity.

- Uses strut pressure sensors and on-board microprocessor to determine payload weight.
- Delivers consistent, accurate payloads and improves efficiency by minimizing overloading and underloading.
- External lights signal loading tool operator when payload is reached.

- On-board computer stores up to 2,400 cycles for analysis of payload weight, cycle times, distances, and actual cycle dates and times.
- A second gear reweigh takes an additional measurement once the truck has reached second gear for improved accuracy.
- System is accurate within ± 5 percent under normal loading conditions over a normal shift.
- Standard LED lamps replace incandescent lamps on the TPMS, extending lamp life by 25 times.

VIMS™ Monitoring System (optional). Caterpillar designed machine monitoring system provides more than 250 machine parameters, critical machine health and payload data in real-time to keep the 777F performing at top production levels.

Road Analysis Control (RAC) (optional). Optional system monitors haul road conditions by measuring frame rack and pitch to improve haul-road maintenance, cycle times, tire life and fuel efficiency.

Product Link (optional). Now available out of the factory, this system streamlines diagnostic efforts, downtime, and maintenance scheduling and costs by providing a two-way communication flow of vital machine data and location information between the dealer and the customer. Product Link provides updates on service meter hours, machine condition, machine location as well as integrated mapping/route planning.

MineStar™ Ready. MineStar information management system helps meet the challenges of the mining industry by linking the machines in the field with business and operating systems to ensure peak performance of mining assets at the lowest possible cost. These products deliver customers everything from real-time machine health information to GPS-guided production aids. The 777F is equipped for quick and easy installation of MineStar information management system products.

Truck Body Systems

Cat designed and built for rugged performance and reliability in the toughest hauling applications.



- **Cat X Body.** The X Body is an upgrade of the Dual Slope in that it incorporates the latest structural designs and can be configured with a variety of 450 BHN steel liner options to meet the specific requirements of the mine. The flat floor design offers reduced wear and better material ejection. Like the Dual Slope – the X Body is designed for durability first.



- **Gateless Coal Body.** This specialized high volume body, available in several sizes, is targeted at dedicated coal haulage applications with minimal impact. It eliminates the tailgate with a kicked up floor design that gives the volume required to meet target payload.

Cat Truck Bodies. Matching the truck body to the application is a critical part of achieving the best value from your 777F. Caterpillar offers a variety of application specific body options. The Caterpillar exclusive 10/10/20 payload guidelines help achieve a balance of excellent payload with safe operation.

Body Options



- **Dual Slope Body.** The original standard body, the Dual Slope body, provides excellent load retention, maintains a low center of gravity with optimum load distribution, reduces shock loading and is available with 400 BHN steel liners or rubber liners. The Dual Slope body is intended for tough applications including greenfield sites and contractor miners.

Custom Body Options. A variety of options, including tail extensions and sideboards, are available to maintain rated payload, reduce spillage and improve hauling efficiencies.

Body/Chassis Integration. Cat Truck Body Systems are designed and matched with the integrated chassis system for optimum structural reliability, durability and long life.

Electronic Hoist Control. Provides the operator with better control of the load when dumping, including over-center load control and modulated control throughout the operating range. The automatic body snubbing feature reduces impact on the frame, hoist cylinders and operator.

Fast Hoist Cycle Times. Two-stage hoist cylinders provide fast dump cycle times of 15 seconds for raise and 13 seconds for lower.

Body Liners. Two liner options are available to help extend body system life. All steel liner wear surfaces are equipped with 400 BHN steel to handle tough impact loads while resisting abrasion. An optional rubber liner delivers long life in high-wear applications and improved operator comfort during loading.

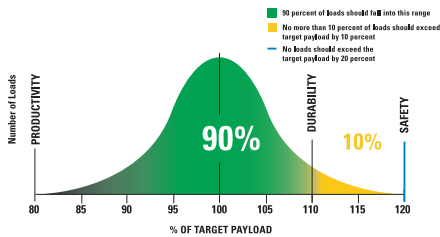

Target Payload Strategy. Your Cat dealer can help you manage to target payload to maximize equipment use, ensure safe operation, increase productivity and lower cost-per-ton.

- Underloading increases costs due to lost payloads, underutilizes equipment, and increases cost-per-ton.



- Overloading causes excessive wear on vehicle components, such as brakes, tires and drive train, reducing component life and increasing maintenance costs and repairs.

Matched Systems. Designed to work as an optimum pass/match system, the 777F is best sized to match the Cat® 992K Wheel Loader, with a four to five pass/match, and the 993K Wheel Loader with four pass/match.

Customer Support

Cat dealers have what it takes to keep trucks productive.

Commitment Makes the Difference.

Cat® dealers offer a wide range of solutions, services and products that help you lower costs, enhance productivity and manage your operation more efficiently. Support goes far beyond parts and service. From the time you select a piece of Cat equipment until the day you rebuild, trade or sell it, the support you get from your Cat dealer makes the difference that counts.

Dealer Capability. Cat dealers provide the level of support you need, on a global scale. Dealer expert technicians have the knowledge, experience, training and tooling necessary to handle your repair and maintenance needs, when and where you need them.

Product Support. Cat dealers believe superior products deserve superior support. When Cat products reach the field, they are supported by a worldwide network of parts distribution facilities, dealer service centers, and technical training facilities to keep your equipment up and running. Cat customers rely on prompt, dependable parts availability and expertise through our global dealer network, ready to meet your needs 24/7.

Service Support. Every piece of Cat equipment is designed and built to provide maximum productivity and operating economy throughout its working life. Cat dealers offer a wide range of service plans that will maximize uptime and return on your investment, including:

- Preventive Maintenance Programs
- Diagnostic Programs, such as Scheduled Oil Sampling and Technical Analysis
- Rebuild and Reman Options
- Customer Support Agreements

Application Awareness. Operating and maintenance costs are influenced by many application and site-specific factors, such as material density, loading position, payload, grades,



speeds, haul road design and maintenance. To optimize total cost of ownership and productivity, your Cat dealer can provide you with a fundamental understanding of the effects application characteristics and operating techniques have on maintenance and operating costs.

Operation. With today's complex products, equipment operators must have a thorough understanding of machine systems and operating techniques to maximize efficiency and profitability. Your Cat dealer can arrange training programs to help operator's improve productivity, decrease downtime, reduce operating costs, enhance safety, and improve return on the investment you make in Cat products.

Technology Products. Cat dealers offer a range of advanced technology products, such as VIMS™ monitoring system and MineStar™ information management system. These products include radio data communications, machine monitoring and diagnostics, fleet management, and haul road maintenance software – all designed to improve fleet efficiency, increase productivity, and lower costs.

www.cat.com. For more complete information on Cat products, dealer services, and industry solutions, visit us on the web at www.cat.com.

Safety

Cat machines and systems are designed with safety as the first priority.

Product Safety. Caterpillar has been and continues to be proactive in developing machines that meet or exceed safety standards. Safety is an integral part of all machine and systems designs.

Integral ROPS Cab. Resiliently mounted to the frame to reduce vibration and sound, the integral ROPS structure, which provides “five-sided protection” for the operator, is designed as an extension of the truck frame.

Payload Guidelines. Safety is integral to maintaining the highest productivity in mining machine operation. Caterpillar 10/10/20 payload guidelines provide a reference for managing payloads.

WAVS Camera (optional). An optional rear vision camera system provides visibility to the rear of the machine through an LCD monitor in the cab. The monitor can be set to activate only when the truck is in reverse, and the display is equipped with a sensor to detect ambient light, which automatically brightens or dims the display.

High Intensity Discharge (HID) Lights (optional). Thirty-five Watt HID lights can replace the standard high beam 65 Watt Halogen lights. The powerful HID lights are almost two times brighter and 50 percent more efficient, improving night time visibility.

Brake Systems. Four corner oil-cooled braking system provides excellent control in slippery conditions. The service brakes and retarding system are actuated by modulated hydraulic pressure, while secondary and parking brake functions are spring applied and hydraulic released. This reliable and durable system ensures braking in the event of complete hydraulic failure. Either the parking or secondary brake systems on this truck will hold it on a grade up to 15 percent while carrying a rated load.



Steering System. A twin, double-acting cylinder steering system is designed to deliver precise control under all loading and underfoot conditions. The steering hydraulic system is separate from the main hydraulic system to prevent cross-contamination and overheating.

Engine Shutoff Switch. A secondary engine shutoff switch is located at ground level.

Electrical System Disconnect. A battery disconnect switch, located directly above the front bumper, provides ground-level lockout of the electrical system.

Ladder/Secondary Egress. Wide stationary stairways and platforms on both sides of the machines, allow easy ingress and egress.

A stairway lamp illuminates the cab access stairs and can be activated at ground level during entry and shut off with a switch in the cab.

Standard Safety Features.

- Slip resistant surfaces
- 75 mm (3 in) wide orange three-point operator restraint
- Heated, wide-angle mirrors
- Body raised indicator
- Guard rails
- Reverse neutralizer when dumping
- Low interior sound level
- Service platform level transmission, hoist and steering disable switch
- Service platform level starter disable switch

Engine

Engine Model	Cat® C32 ACERT™	
Gross Power – SAE J1995	758 kW	1,016 hp
Net Power – SAE J1349	700 kW	938 hp
Net Power – ISO 9249	700 kW	938 hp
Net Power – 80/1269/EEC	700 kW	938 hp
Number of Cylinders	12	
Peak Torque	4716 N·m	3,478 lb ft
Bore	145 mm	5.7 in
Stroke	162 mm	6.4 in
Displacement	32.1 L	1,959 in ³

- Power ratings apply at 1,750 rpm when tested under the specified condition for the specified standard.
- Ratings based on SAE J1995 standard air conditions of 25° C (77° F) and 100 kPa (29.61 Hg) barometer. Power based on fuel having API gravity of 35 at 16° C (60° F) and an LHV of 42 780 kJ/kg (18,390 BTU/lb) when engine is used at 30° C (86° F).
- No engine derate to 3658 m (12,000 ft) altitude.
- Compliant with U.S. Environmental Protection Agency Tier 2 and European Union Stage II emissions standards.

Weights – Approximate

Target Gross Machine Operating Weight	163 293 kg	360,000 lb
Chassis Weight	48 008 kg	105,839 lb
Body Weight	16 420 kg	36,200 lb

- Chassis weight with 100% fuel, hoist, body mounting group, rims and tires.
- Body weight varies depending on how body is equipped.

Operating Specifications

Nominal Payload Class	90.7 tonnes	100 tons
Body Capacity – SAE 2:1	60.2 m ³	78.8 yd ³
Top Speed – Loaded	64.5 km/h	40.1 mph

- Refer to the Caterpillar 10/10/20 Payload Guidelines for maximum gross machine weight limitations.
- Capacity with dual slope body.

Transmission

Forward 1	10.5 km/h	6.5 mph
Forward 2	14.3 km/h	8.9 mph
Forward 3	19.3 km/h	12 mph
Forward 4	26.1 km/h	16.2 mph
Forward 5	35.4 km/h	22 mph
Forward 6	47.6 km/h	29.6 mph
Forward 7	64.5 km/h	40.1 mph
Reverse	12.1 km/h	7.5 mph

- Maximum travel speeds with standard 27.00R49 (E4) tires.

Final Drives

Differential Ratio	2.74:1	
Planetary Ratio	7.00:1	
Total Reduction Ratio	19.16:1	

Brakes

Brake Surface – Front	40 225 cm ²	6,235 in ²
Brake Surface – Rear	102 116 cm ²	15,828 in ²
Brake Standards	ISO 3450: 1996	

- Target Gross Machine Operating Weight is 163 293 kg (360,000 lb).

Body Hoists

Pump Flow – High Idle	492 L/min	130 gal/min
Relief Valve Setting – Raise	18 950 kPa	2,750 psi
Relief Valve Setting – Lower	3450 kPa	500 psi
Body Raise Time – High Idle	15 Seconds	
Body Lower Time – Float	13 Seconds	
Body Power Down – High Idle	13 Seconds	

Capacity – Dual Slope – 100% fill factor

Struck	41.9 m ³	54.8 yd ³
Heaped 2:1 (SAE)	60.2 m ³	78.8 yd ³

Weight Distributions – Approximate

Front Axle – Empty	45%
Front Axle – Loaded	33%
Rear Axle – Empty	55%
Rear Axle – Loaded	67%

Suspension

Effective Cylinder Stroke – Front	319 mm	12.6 in
Effective Cylinder Stroke – Rear	165 mm	6.5 in
Rear Axle Oscillation	5.4°	

Service Refill Capacities

Fuel Tank	1136 L	300 gal
Cooling System	232 L	61 gal
Crankcase	114 L	30 gal
Differentials and Final Drives	264 L	70 gal
Steering Tank	30 L	8 gal
Steering System (Includes Tank)	57 L	15 gal
Torque Converter/Brake/ Hoist Hydraulic Tank	189 L	50 gal
Torque Converter/Brake/ Hoist System (Includes Tank)	504 L	133 gal
Transmission Sump Tank	47 L	12 gal
Transmission System (Includes Sump Tank)	246 L	65 gal

Tires

Standard Tire	27.00R49 (E4)
---------------	---------------

- Productive capabilities of the 777F truck are such that, under certain job conditions, TKPH (TMPH) capabilities of standard or optional tires could be exceeded and, therefore, limit production.
- Caterpillar recommends the customer evaluate all job conditions and consult the tire manufacturer for proper tire selection.

ROPS

ROPS/FOPS Standards

- ROPS (Rollover Protective Structure) for cab offered by Caterpillar meets ISO 3471:1994 ROPS criteria.
- FOPS (Falling Objects Protective Structure) meets ISO 3449:1992 Level II FOPS criteria.

Sound

Sound Standards

- The operator sound pressure level measured according to ANSI/J919 APR95 is 76 dB(A) for cab offered by Caterpillar, when properly installed, maintained and tested with doors and windows closed, engine speed at high idle, and fan at medium setting.
- The exterior sound pressure level for the standard machine measured at a distance of 15 m (49 ft) according to the test procedures specified in SAE J88 APR95, mid-gear moving operation is 84 dB(A).
- Hearing protection may be needed when operating with an open operator station and cab (when not properly maintained or doors/windows open) for extended periods or in a noisy environment.

Steering

Steering Standards	SAE J1511 FEB94 ISO 5010:1992	
Steer Angle	30.5°	
Turning Diameter – Front	25.3 m	83 ft
Machine Clearance Turning Diameter	28.4 m	93.2 ft

- Target Gross Machine Operating Weight is 163 293 kg (360,000 lb).

Dimensions

All dimensions are approximate.

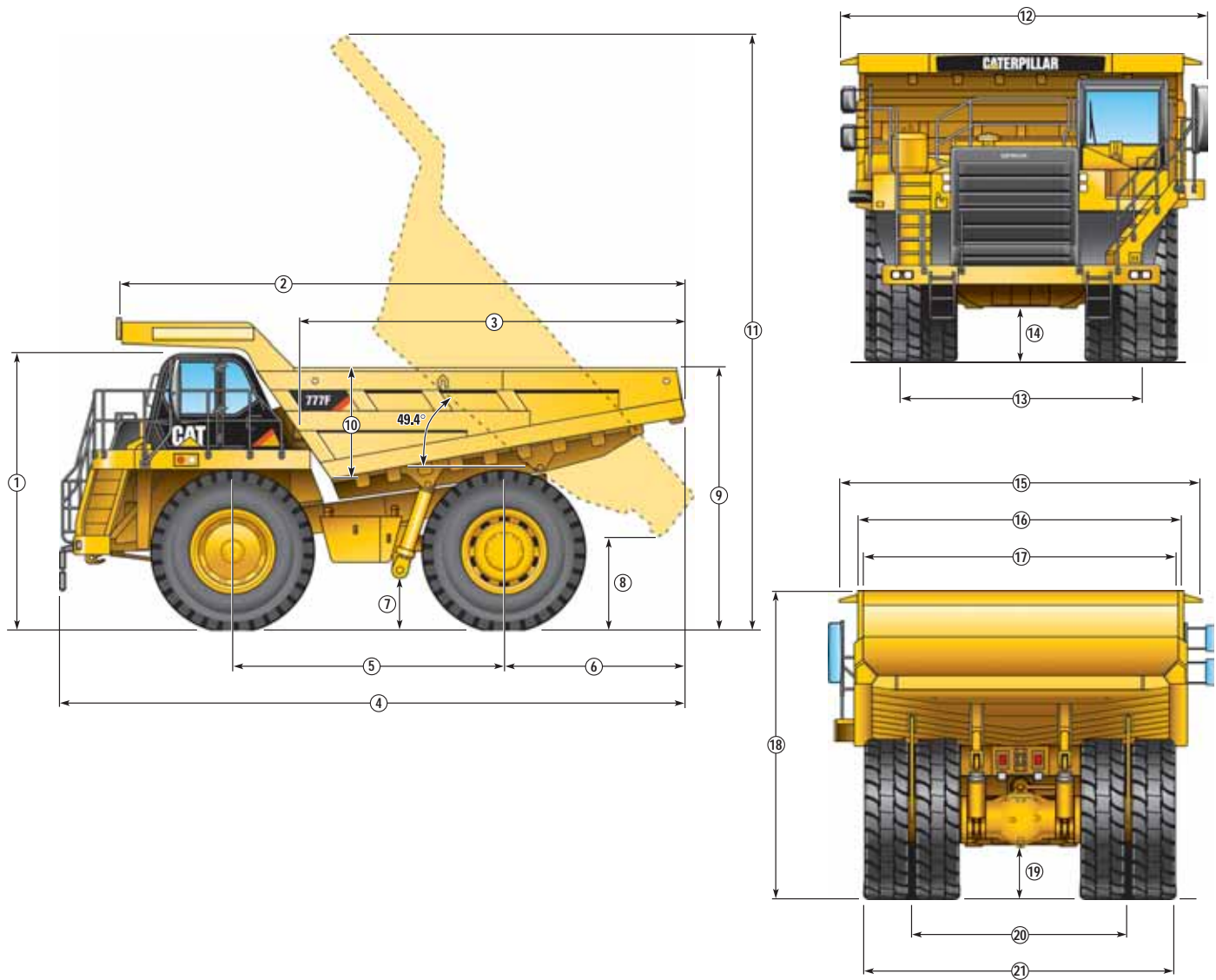

1	Height to top of ROPS	4715 mm	15 ft 6 in
2	Overall Body Length	9830 mm	32 ft 3 in
3	Inside Body Length	6580 mm	21 ft 7 in
4	Overall Length	10 535 mm	34 ft 7 in
5	Wheelbase	4560 mm	15 ft
6	Rear Axle to Tail	3062 mm	10 ft 1 in
7	Ground Clearance	896 mm	2 ft 11 in
8	Dump Clearance	965 mm	3 ft 2 in
9	Loading Height - Empty	4380 mm	14 ft 4 in
10	Inside Body Depth - Max	1895 mm	6 ft 3 in
11	Overall Height - Body Raised	10 325 mm	33 ft 11 in

12	Operating Width	6494 mm	21 ft 4 in
13	Centerline Front Tire Width	4170 mm	13 ft 8 in
14	Engine Guard Clearance	864 mm	2 ft 10 in
15	Overall Canopy Width	6050 mm	19 ft 10 in
16	Outside Body Width	5524 mm	18 ft 2 in
17	Inside Body Width	5200 mm	17 ft 1 in
18	Front Canopy Height	5170 mm	17 ft
19	Rear Axle Clearance	880 mm	2 ft 11 in
20	Centerline Rear Dual Tire Width	3576 mm	11 ft 9 in
21	Overall Tire Width	5223 mm	17 ft 2 in

Weight/Payload Calculation

(Example)

	Dual Slope					
	No Liner		Steel Liner (16 mm)		Rubber Liner (102 mm)	
Target Gross Machine Weight*	163 293 kg	360,000 lb	163 293 kg	360,000 lb	163 293 kg	360,000 lb
Empty Chassis Weight*	48 008 kg	105,839 lb	48 008 kg	105,839 lb	48 008 kg	105,839 lb
Body Weight	16 420 kg	36,200 lb	16 420 kg	36,200 lb	16 420 kg	36,200 lb
Body Liner	—	—	5767 kg	12,714 lb	6766 kg	14,914 lb
Empty Machine Weight	64 428 kg	142,039 lb	70 195 kg	154,753 lb	71 194 kg	156,953 lb
Attachments**	—	—	—	—	—	—
Fuel Tank Size	1136 L	300 gal	1136 L	300 gal	1136 L	300 gal
Fuel Tank – 90% fill	861 kg	1,898 lb	861 kg	1,898 lb	861 kg	1,898 lb
Debris Allowance	1921 kg	4,234 lb	1921 kg	4,234 lb	1921 kg	4,234 lb
Empty Operating Weight**	67 210 kg	148,173 lb	72 977 kg	160,885 lb	73 976 kg	163,085 lb
Target Payload*	96 083 kg	211,827 lb	90 316 kg	199,115 lb	89 317 kg	196,915 lb
Target Payload*	96.1 tonnes	105.9 tons	90.3 tonnes	99.5 tons	89.3 tonnes	98.5 tons

* Refer to Caterpillar Mining Trucks Payload Guidelines

** Includes weight of all attachments

Gradeability/Speed/Rimpull

To determine gradeability performance: Read from gross weight down to the percent of total resistance. Total resistance equals actual percent grade plus 1% for each 10 kg/t (20 lb/ton) of rolling resistance. From this weight-resistance point, read

horizontally to the curve with the highest obtainable gear, then down to maximum speed. Usable rimpull will depend upon traction available and weight on drive wheels.

- Direct Drive
- - - - - Torque Converter Drive
- E - Typical Field Empty Weight
- L - Target Gross Machine Operating Weight 163 293 kg (360,000 lb)

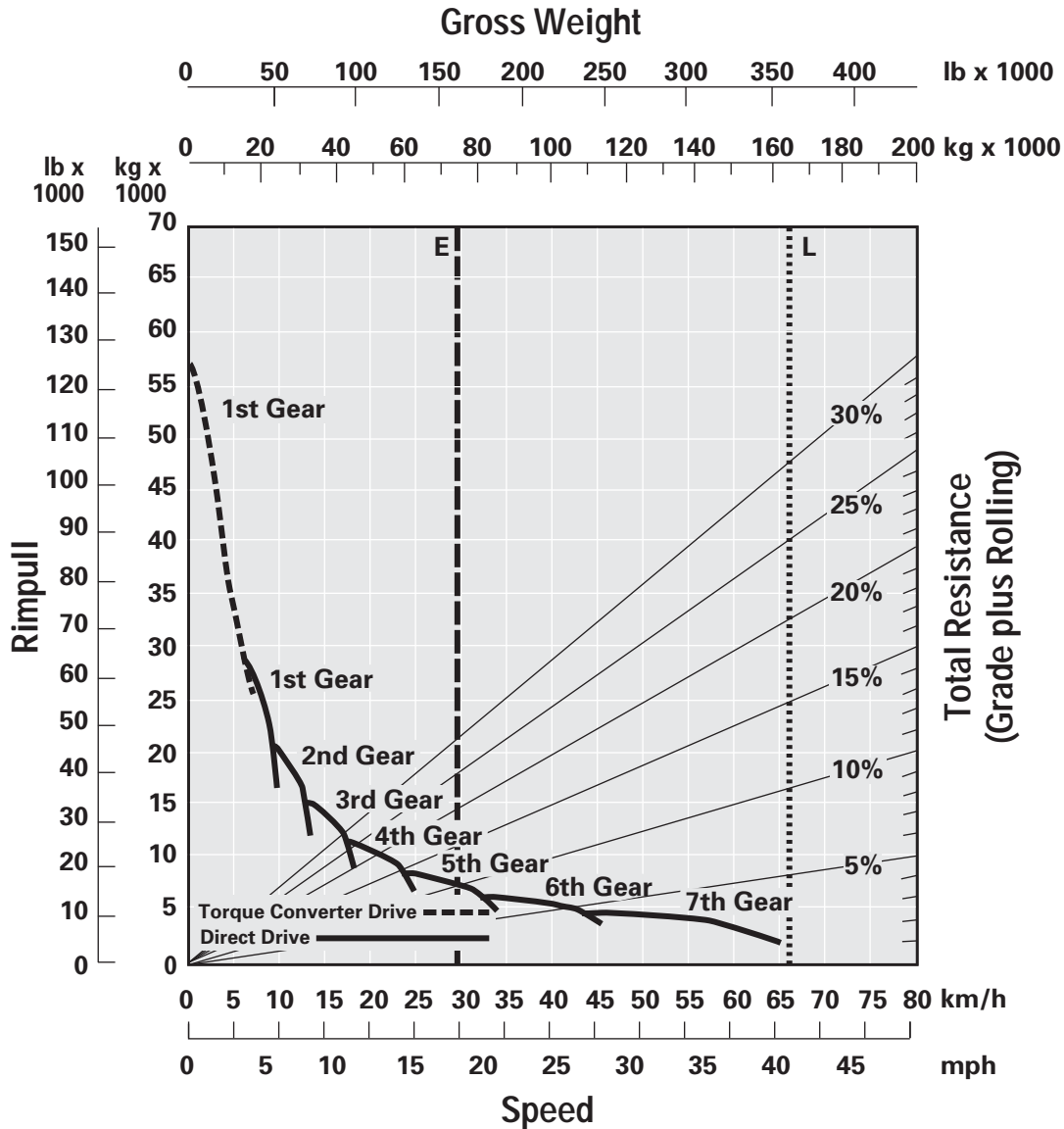

Retarding Performance

To determine retarding performance: Add lengths of all downhill segments and, using this total, refer to proper retarding chart. Read from gross weight down to the percent effective grade. Effective grade equals actual % grade minus 1% for each 10 kg/t (20 lb/ton) of rolling resistance. From this weight-effective grade point, read horizontally to the curve with the highest obtainable gear, then down to maximum descent speed brakes can properly handle without exceeding

cooling capacity. The following charts are based on these conditions: 32° C (90° F) ambient temperature, at sea level, with 27.00 R49 tires.

NOTE: Select the proper gear to maintain engine rpm at the highest possible level, without overspeeding the engine. If cooling oil overheats, reduce ground speed to allow transmission to shift to the next lower speed range.

- With ARC Only
- - - - - ARC and Engine Brake
- E – Typical Field Empty Weight
- L – Target Gross Machine Operating Weight 163 293 kg (360,000 lb)

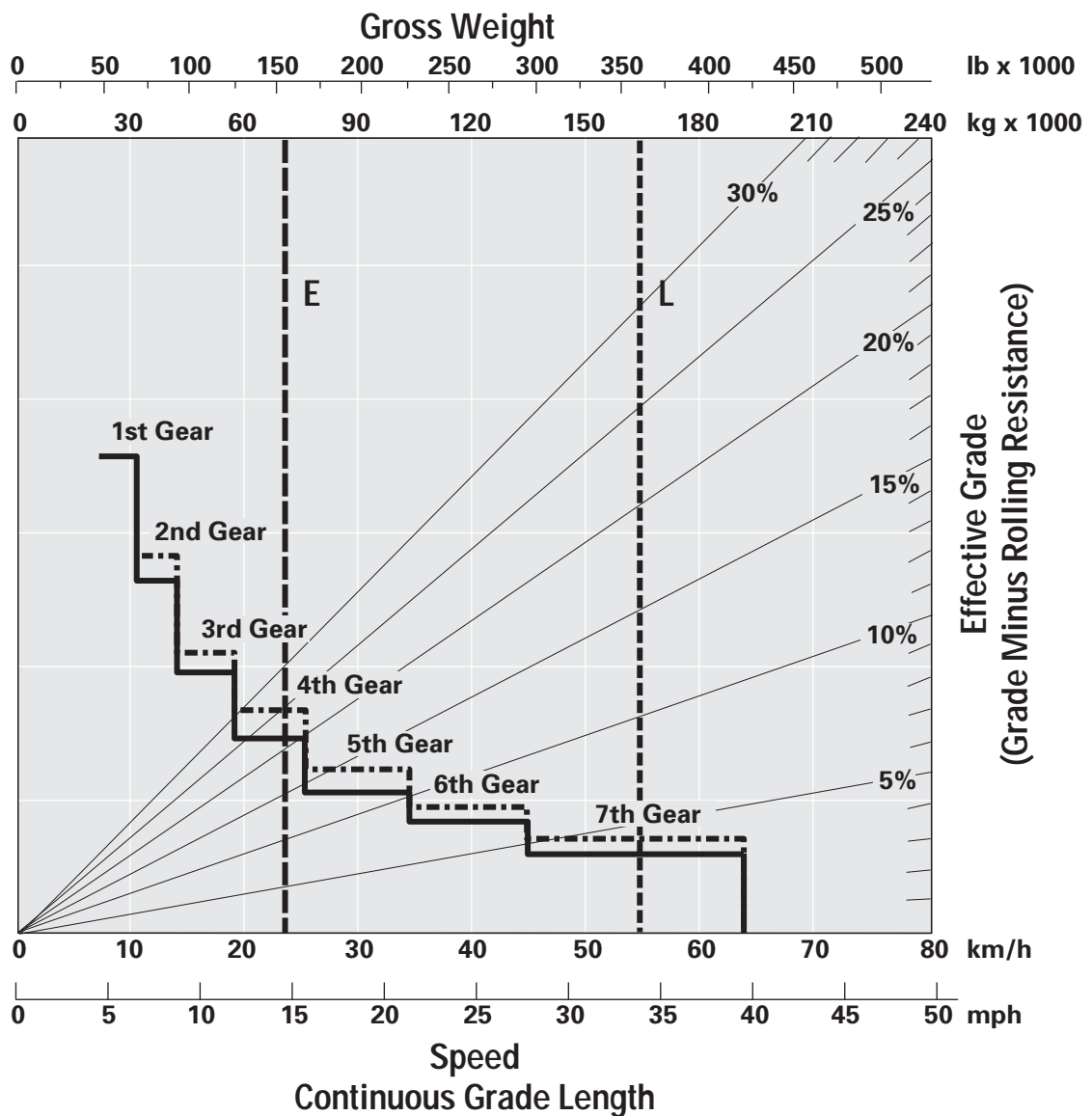

Retarding Performance

— With ARC Only
 - - - - - ARC and Engine Brake
 E - Typical Field Empty Weight
 L - Target Gross Machine Operating Weight 163 293 kg (360,000 lb)

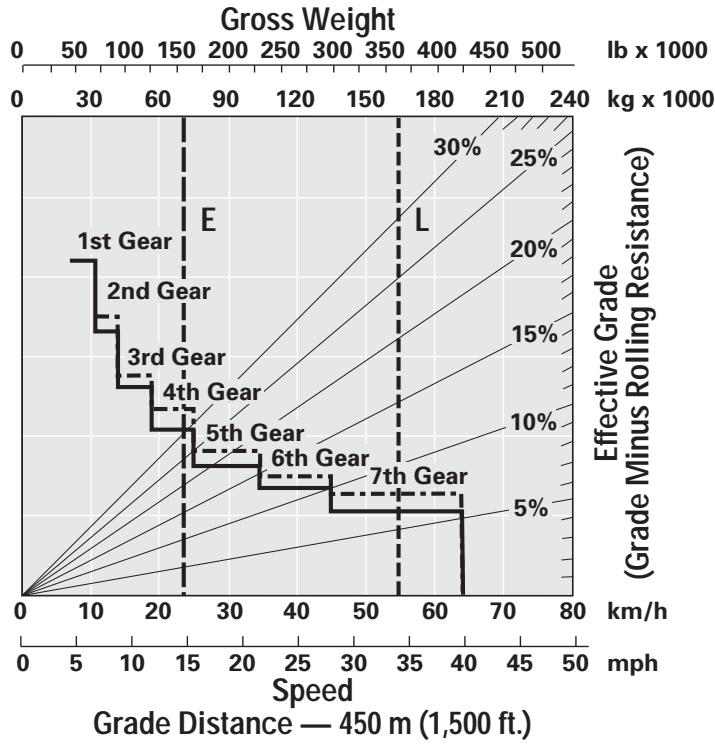

— With ARC Only
 - - - - - ARC and Engine Brake
 E - Typical Field Empty Weight
 L - Target Gross Machine Operating Weight 163 293 kg (360,000 lb)

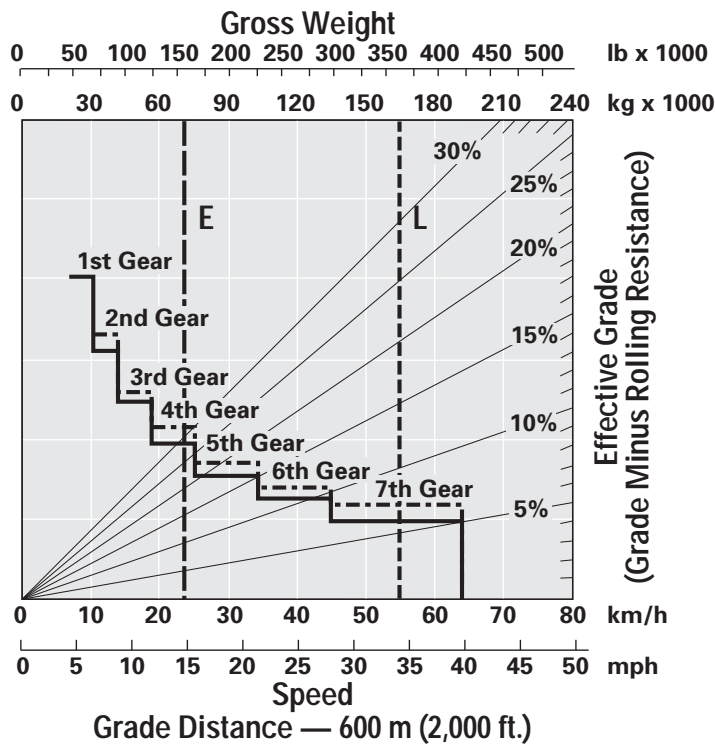

Retarding Performance

— With ARC Only
 - - - - - ARC and Engine Brake
 E - Typical Field Empty Weight
 L - Target Gross Machine Operating Weight 163 293 kg (360,000 lb)

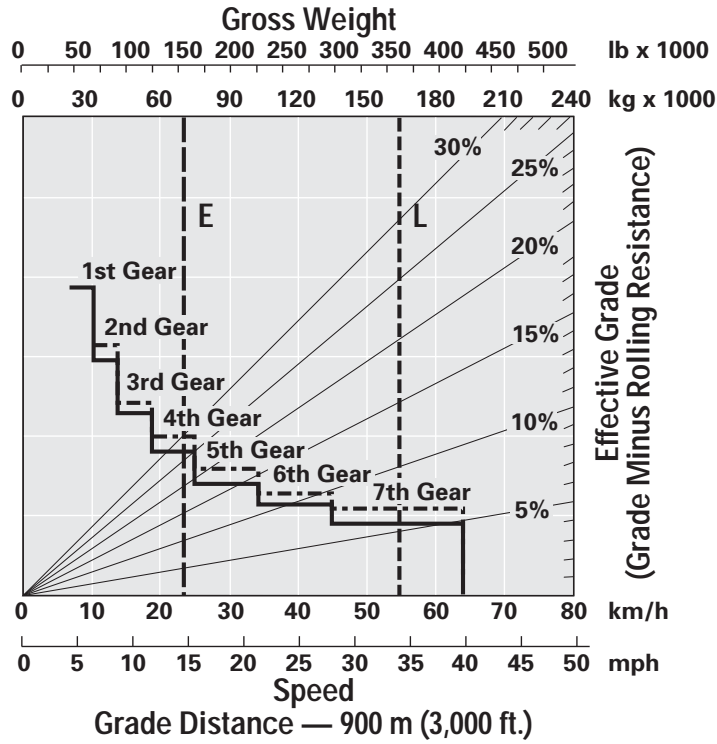

— With ARC Only
 - - - - - ARC and Engine Brake
 E - Typical Field Empty Weight
 L - Target Gross Machine Operating Weight 163 293 kg (360,000 lb)

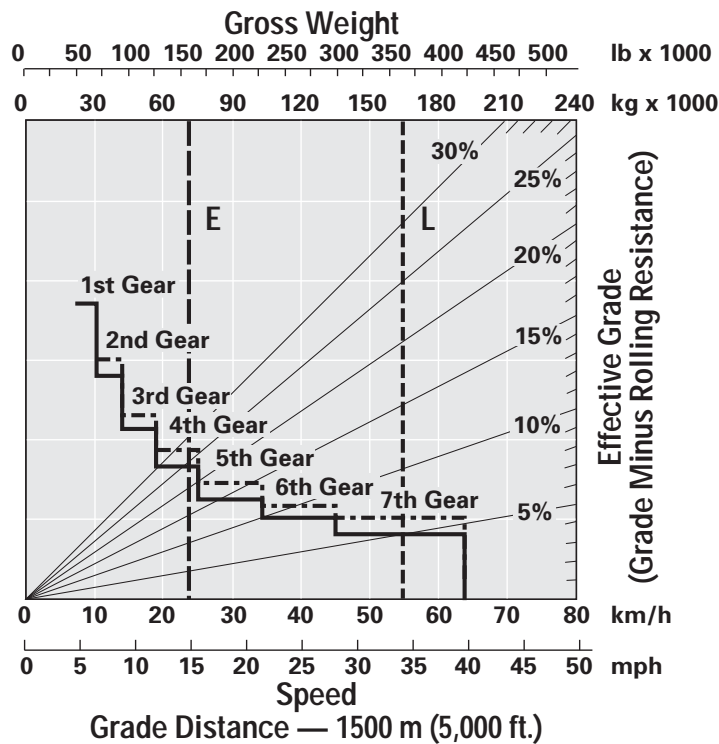

Standard Equipment

Standard equipment may vary. Consult your Cat dealer for details.

OPERATOR ENVIRONMENT

- Air conditioning
- Ashtray and cigarette lighter
- Coat hook
- Cup holders (4)
- Diagnostic connection port, 24V
- Entertainment Radio Ready
 - 5 amp converter
 - Speakers
 - Antenna
 - Wiring harness
- Gauges/indicators:
 - Air cleaner service indicator
 - Brake oil temperature gauge
 - Coolant temperature gauge
 - Engine overspeed indicator
 - Fuel level
 - Hour meter
 - Speedometer/odometer
 - Tachometer
 - Transmission gear indicator
- Heater/defroster, (11 070 kCal/43,930 BTU)
- Hoist lever
- Horn
- Light, dome/courtesy
- Load counter, automatic
- Messenger display unit
- Mirrors, heated (left/right)
- Power port, 24V and 12V (2)
- ROPS cab, insulated/sound suppressed
- Seat, Caterpillar Comfort
 - Full air suspension
 - Retractable, 3-point seat belt with shoulder harness
- Seat, training with lap belt
- Steering wheel, padded, tilt and telescopic
- Storage compartment
- Sun visor, tinted glass
- Throttle lock
- Window, hinged access
- Windshield wiper (intermittent) and washer

POWER TRAIN

- Cat[®] C32 Engine with ACERT™ Technology
 - 12-cylinder diesel
 - Air-to-Air Aftercooler (ATAAC)
 - Air cleaner with precleaner (2)
 - Automatic cold mode idle control
 - Electric priming pump
 - Electric cold weather starter (2 starters, 4 batteries)
 - Ether starting aid
 - Exhaust, body heat
 - Fuel filter/water separator
 - QuickEvac™ System with engine prelube
 - Turbocharger (2)
- Braking system:
 - Automatic Retarder Control (ARC)
 - Brake release motor (towing)
 - Manual retarder
 - Oil-cooled, multiple disc (front/rear)
- Transmission:
 - 7-speed automatic powershift w/Electronic Clutch Pressure Control (ECPC)
 - Body up shift inhibitor
 - Controlled throttle shifting
 - Directional shift management
 - Downshift inhibitor
 - Neutral start switch
 - Neutral coast inhibitor
 - Reverse shift inhibitor
 - Reverse neutralizer during dumping
 - Programmable top gear selection

ANTIFREEZE

- Extended Life Coolant to -35° C (-30° F)

ELECTRICAL

- Alarm, backup
- Alternator, 95-amp
- Auxiliary jump start receptacle
- Batteries, maintenance-free, 12V (4), 190 amp-hour
- Electrical system, 25-amp, 24V to 12V converter
- Lighting system:
 - Backup light (halogen)
 - Directional signals/hazard warning, (front/rear LED)
 - Headlights (8), halogen with dimmer
 - Operator access courtesy lights
 - Side profile lights
 - Stop/tail lights LED
- MineStar™ Ready
- Product Link Ready

Standard Equipment

Standard equipment may vary. Consult your Cat dealer for details.

GUARDS

- Engine crankcase
- Driveline
- Fan and Air Conditioning

SUSPENSION SYSTEM

- Suspension, rear (European Union compliant)

OTHER STANDARD EQUIPMENT

- Body mounting group
- Body safety pin (secures body in up position)
- Body down indicator
- CD-ROM parts book
- Center mounted rims
- Direct drive fan
- Fuel tank, 1136 L (300 gal)
- Fast fuel system, pressurizing
- Ground level battery disconnect
- Ground level engine shutdown
- Ground level grease fittings
- Rims, 19.5 * 49 in
- Rock ejectors
- Service platform level engine start/disable switch
- Service platform level transmission, hoist and steering disable switch
- Supplemental steering (automatic)
- Tie down eyes
- Tow hooks, front
- Tow pin, rear
- Vandalism protection locks

Optional Equipment

Optional equipment may vary. Consult your Cat dealer for details.

- Body, Gateless Coal
- Body, X
- Body Liner, Dual Slope, Steel, 16 mm
- Body Liner, Dual Slope, Rubber, 102 mm
- Cat Compression Brake
- Automatic Lubrication System
- Clustered Grease Fittings
- Engine Coolant Heater
- Extended Life Disc Brakes
- Fast Fuel System, Non-pressurizing
- Front Dry Brakes
- Fuel Heater
- Fuel Tank, 1325 L (350 gal)
- HID Lights
- Hoist Control

- Muffler, Full Time
- Muffler, Adjustable Exhaust Diverter
- Oil Renewal System (ORS)
- Product Link
- Road Analysis Control (RAC)
- Variable Speed Fan, Rockford
- Traction Control System (TCS)
- Truck Production Management System (TPMS)
- VIMS™ Monitoring System
- Visibility Package, Perimeter
- Camera, Rear Vision
- Wheel Chocks
- Wiggins High Speed Oil Change
- Wiggins Service Center

777F Off-Highway Truck

For more complete information on Cat products, dealer services,
and industry solutions, visit us on the web at www.cat.com

© 2010 Caterpillar
All Rights Reserved
Printed in U.S.A.

Materials and specifications are subject to change without notice.
Featured machines in photos may include additional equipment.
See your Cat dealer for available options.

AEHQ5749-02 (7-10)
Replaces AEHQ5749-01

CAT, CATERPILLAR, SAFETY.CAT.COM, their respective logos, "Caterpillar Yellow"
and the "Power Edge" trade dress, as well as corporate and product identity used
herein, are trademarks of Caterpillar and may not be used without permission.

